



MLC Semester 2 Physics Examination, 2010

Question/Answer Booklet

PHYSICS

Stage 3

Please place your name in this box

Time allowed for this paper

Reading time before commencing work: ten minutes

Working time for paper: three hours

Materials required/recommended for this paper

To be provided by the supervisor

This Question/Answer Booklet
Formulae and Constants Sheet

To be provided by the candidate

Standard items: pens, pencils, eraser, correction fluid, ruler, highlighters

Special items: non-programmable calculators satisfying the conditions set by the Curriculum Council for this course

Important note to candidates

No other items may be taken into the examination room. It is **your** responsibility to ensure that you do not have any unauthorised notes or other items of a non-personal nature in the examination room. If you have any unauthorised material with you, hand it to the supervisor **before** reading any further.

Structure of this paper

Section	Number of questions available	Number of questions to be answered	Suggested working time (minutes)	Marks available	Percentage of exam
Section One: Short response	11	11	45	40	25
Section Two: Problem-solving	7	7	90	80	50
Section Three: Comprehension	2	2	45	40	25
					100

Instructions to candidates

1. The rules for the conduct of Western Australian external examinations are detailed in the *Year 12 Information Handbook 2010*. Sitting this examination implies that you agree to abide by these rules.
2. Write answers in this Question/Answer Booklet.
3. You must be careful to confine your responses to the specific questions asked and to follow any instructions that are specific to a particular question.
4. Working or reasoning should be clearly shown when calculating or estimating answers.
5. Spare pages are included at the end of this booklet. They can be used for planning your responses and/or as additional space if required to continue an answer.
 - Planning: If you use the spare pages for planning, indicate this clearly at the top of the page.
 - Continuing an answer: If you need to use the space to continue an answer, indicate in the original answer space where the answer is continued, i.e. give the page number. Fill in the number of the question(s) that you are continuing to answer at the top of the page.

Section One: Short response**25% (40 Marks)**

This section has **eleven (11)** questions. Answer **all** questions. Write your answers in the space provided.

Spare pages are included at the end of this booklet. They can be used for planning your responses and/or as additional space if required to continue an answer.

- Planning: If you use the spare pages for planning, indicate this clearly at the top of the page.
- Continuing an answer: If you need to use the space to continue an answer, indicate in the original answer space where the answer is continued, i.e. give the page number. Fill in the number of the question(s) that you are continuing to answer at the top of the page.

Suggested working time for this section is 45 minutes.

Question 1**(3 marks)**

In the Moomba “Birdman” Event participants run off a horizontal platform and launch themselves into space to “fly” into the waters of the Yarra River, Melbourne, 3.00 m below them. The amount of “lift” supplied by their apparatus varies from zero to not very much.

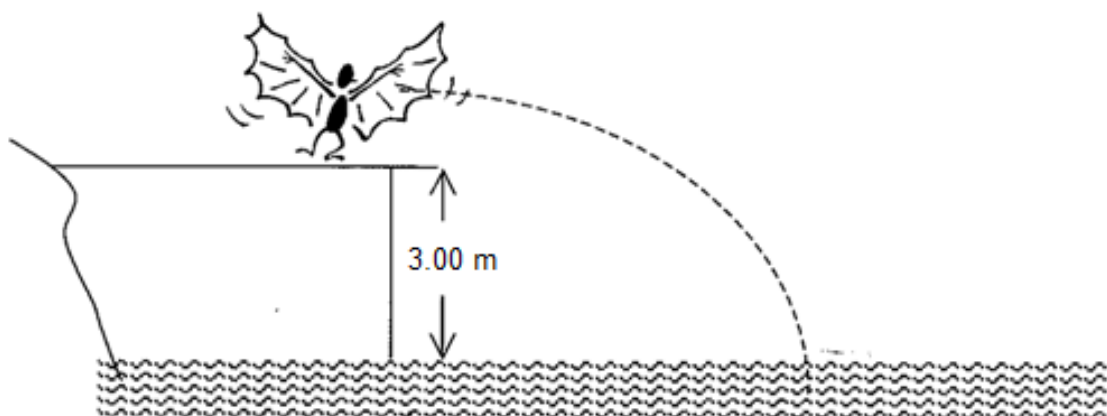

One of the “flyers” launches into space at a speed of 4.50 m s^{-1} horizontally. They are only in it for fun and their equipment consists of “fairy wings” which supply no lift. They plummet to the water. How far from their launch point do they travel horizontally?

Question 2

(3 marks)

The questions below refer to the following diagram representing a section of wave motion.

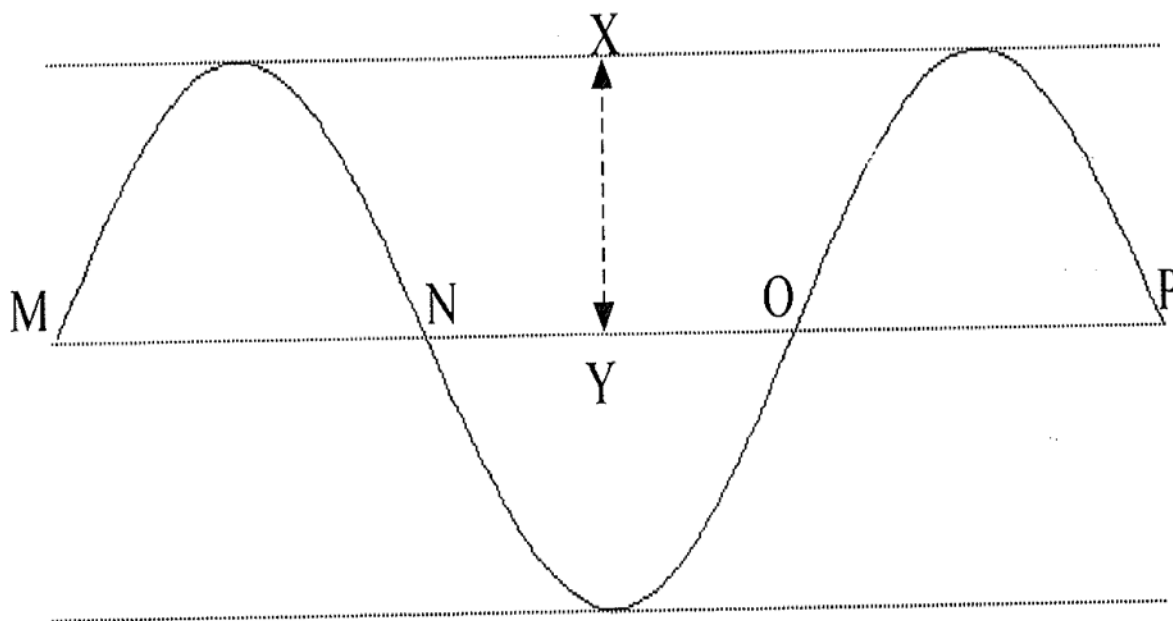

For each of the questions below select your answer from the following key and place your answer in the box:

- A. Amplitude
- B. Frequency
- C. Wavelength
- D. Period
- E. None of these

(a) The time for the wave disturbance to travel from point M to point O is called the: (1 mark)

(b) The distance from point O to point P is called the: (1 mark)

(c) Point X to point Y represents the wave's: (1 mark)

Question 3**(3 marks)**

The resolving power of any telescope defines whether an observer can clearly see two distant stars as two separate images. An angle of 10^{-5} radians between two clear images is considered to be the minimum acceptable. This angle is denoted by Φ in the equation

$$\Phi = \frac{\lambda}{D}$$

where λ is the wavelength of the radiation received and
D is the diameter of the receiving dish or antenna

An optical telescope with a 10.0 m diameter dish can collect useful information in the optical range of wavelengths. The proposed Square Kilometre Array radio wave telescope, intended to detect electromagnetic radiation at a wavelength of 21.0 cm, needs to cover an area of hundreds of square kilometres. Explain this difference.

Question 4**(4 marks)**

A cathode ray oscilloscope contains two parallel plates, AB and CD, with a high voltage (potential difference) across them as shown below.

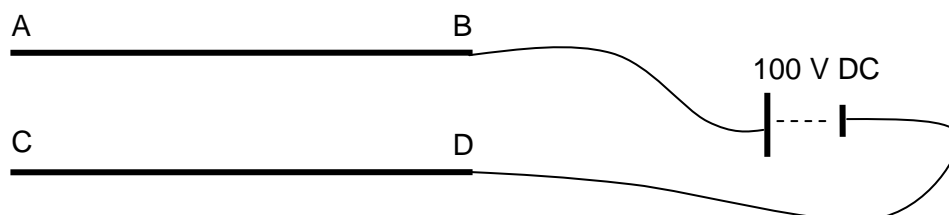

- (a) Draw the electric field pattern between the plates AB and CD. (2 marks)
- (b) Calculate the electric field intensity if the battery has a voltage of 1.00×10^2 V DC and the plate separation is 2.00 cm. (2 marks)

Question 5**(4 marks)**

The force that holds the protons and neutrons together in the nucleus is known as the strong nuclear force. This force only acts on particles known as hadrons of which protons and neutrons are members. Hadrons are thought to be made up of quarks having non integer charges. All hadrons are made of three quarks.

These quarks have different charges. The up quark has a charge of $+\frac{2}{3}e$ while the down quark has a charge of $-\frac{1}{3}e$. 'e' is the charge on an electron.

(a) List the quarks in a proton and justify your answer. (2 marks)

(b) List the quarks in a neutron and justify your answer. (2 marks)

Question 6**(4 marks)**

A beam is supported by two pillars A and B. Pillar A is at the left hand edge of the beam and pillar B is 0.750 m away from the left hand edge. The beam is 3.00 m in length and has a mass of 9.00×10^2 kg. If a man, of mass 85.0 kg, is standing on the extreme right hand edge of the beam, calculate the force acting on pillar A.

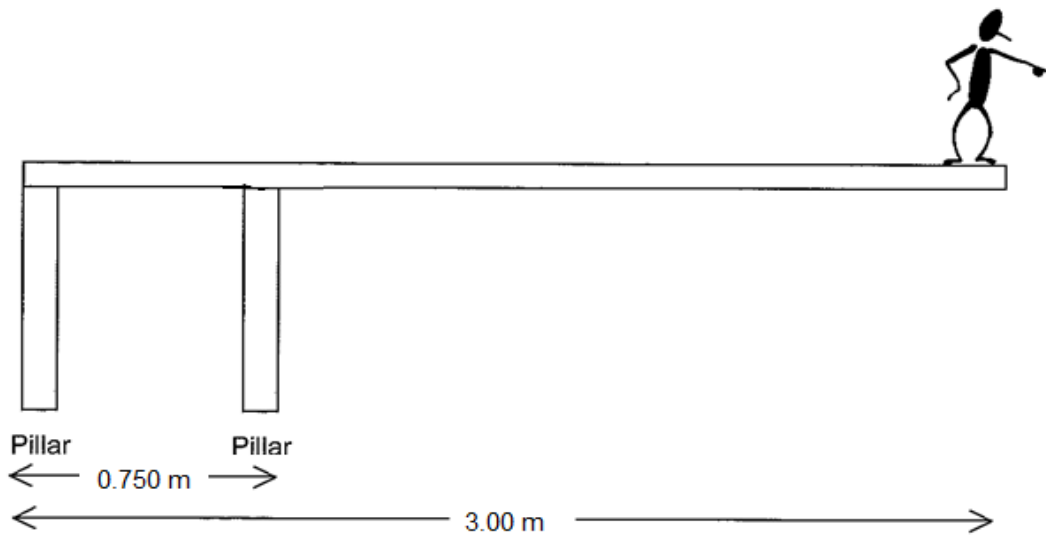

Question 7

(3 marks)

The diagrams below show three different experiments conducted in a laboratory.

Diagram (1) below shows, on the galvanometer, that the current is $6 \mu\text{A}$ when the magnet is moved up through the coil connected to the galvanometer.

Diagram (2) shows the magnet being moved down through the coil and diagram (3) shows the magnet stationary within the coil.

- (a) CLEARLY draw on the galvanometer for diagram (2) and diagram (3), to show what the reading would be. (1 mark)
- (b) Justify your answer to part (a) with an explanation for each situation. (2 marks)

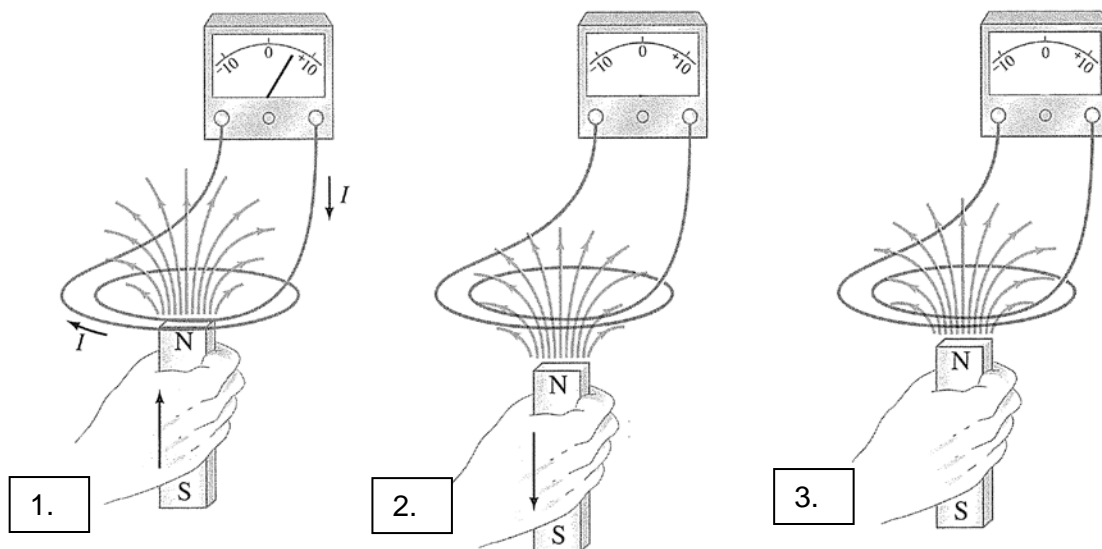

Question 8**(6 marks)**

The banking of curves can reduce the chance of skidding, as the normal force exerted by a banked road will have a component toward the centre of the circle, thus reducing the reliance on friction. Heading onto the Kwinana Freeway from the Mounts Bay Road on-ramp, the speed limit is 40.0 km h^{-1} . If the radius of curvature of the banked ramp is 50.0 m , calculate the angle of the banking on the on-ramp. Show all working.

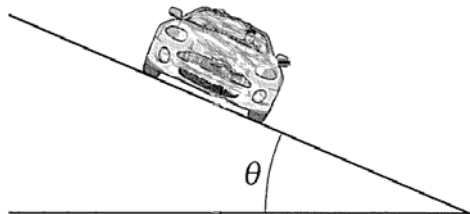

Question 9

(4 marks)

A compact disc spins at 4000 revolutions per minute, and has a radius of 6.00×10^{-2} m. A dust particle of mass 1.00×10^{-4} kg rests on the outer edge of the disc. Calculate the magnitude of the frictional force required to prevent the dust particle from flying off the spinning disc.

Question 10

(2 marks)

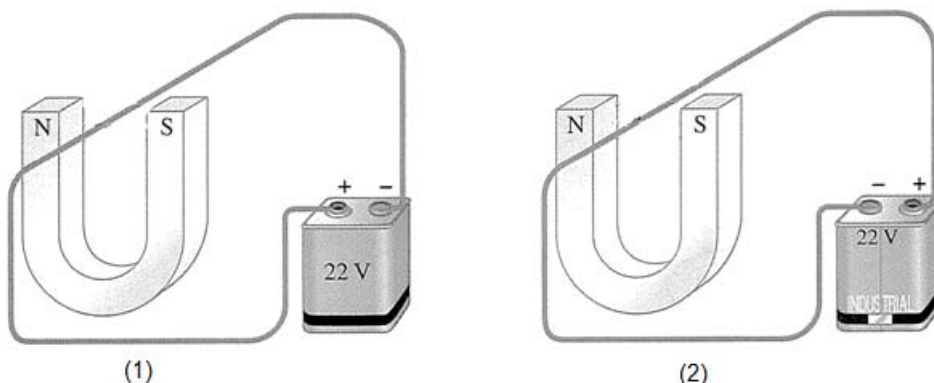

Diagram (1) and diagram (2) above show two different scenarios. Each scenario has a power supply with a permanent magnet and a conductor, free to move within the magnetic field.

Fill in the table below with one observation that could be made for each scenario.

Diagram	Observation
1	
2	

Question 11**(4 marks)**

A projectile is launched from ground level with a speed of $u \text{ m s}^{-1}$ at an angle θ . Show that, if the projectile lands back at ground level, the range of the projectile S_H is given by the formula:

$$S_H = \frac{u^2 \sin 2\theta}{g}. \text{ (Note: } 2 \sin\theta \cos\theta = \sin 2\theta\text{)}$$

End of Section One

Section Two: Problem-solving**50% (80 Marks)**

This section has **seven (7)** questions. You must answer **all** questions. Write your answers in the space provided.

Spare pages are included at the end of this booklet. They can be used for planning your responses and/or as additional space if required to continue an answer.

- Planning: If you use the spare pages for planning, indicate this clearly at the top of the page.
- Continuing an answer: If you need to use the space to continue an answer, indicate in the original answer space where the answer is continued, i.e. give the page number. Fill in the number of the question(s) that you are continuing to answer at the top of the page.

Suggested working time for this section is 90 minutes.

Question 12**(12 marks)**

A farmhouse is supplied electricity from a transformer 4.00 km away. The input voltage of the transformer is 60.0 kV and the output voltage of the transformer is 240 V. When an electric hot water system is used inside the farmhouse the measured voltage across the heater is 210 V. The resistance of the heater is 30.0 Ω .

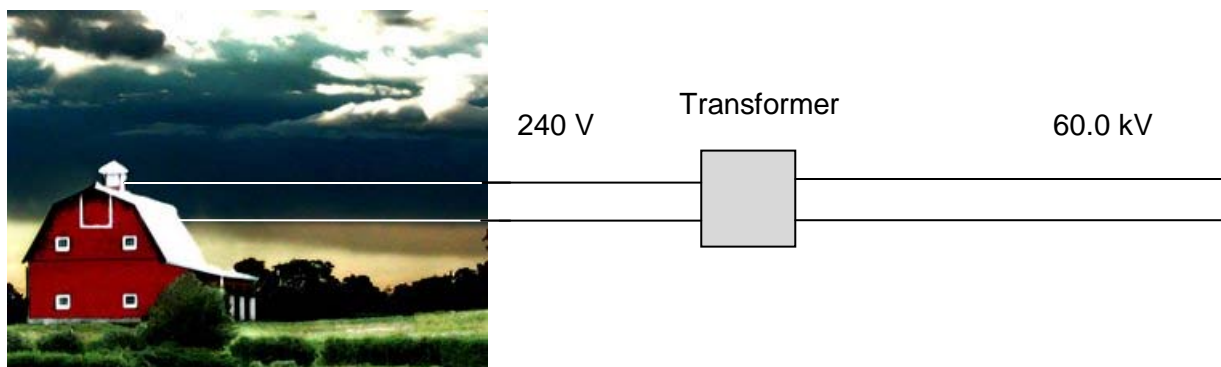

(a) Calculate the turns ratio of the transformer. (1 mark)

(b) Calculate the current to the hot water system. (2 marks)

(c) Calculate the power of the hot water system. (2 marks)

(d) Calculate the resistance of the cables supplying electricity to the farmhouse. (2 marks)

(e) Calculate the amount of energy dissipated as heat in the cables every second. (3 marks)

(f) The country police station is further away from the transformer than the farmhouse. Compare the voltage available at the police station to the voltage available at the farmhouse. Explain your reasoning. (2 marks)

Question 13

(12 marks)

The diagram below shows a glass globe containing a heated filament that emits electrons by thermionic emission. Initially, the space inside the globe is a vacuum. The electrons are attracted to, and then pass through, a hollow conical anode. This forms a narrow beam of electrons.

The electron beam then enters a region of uniform magnetic field. The magnitude of this field can be changed.

This device can be used for a range of experiments.

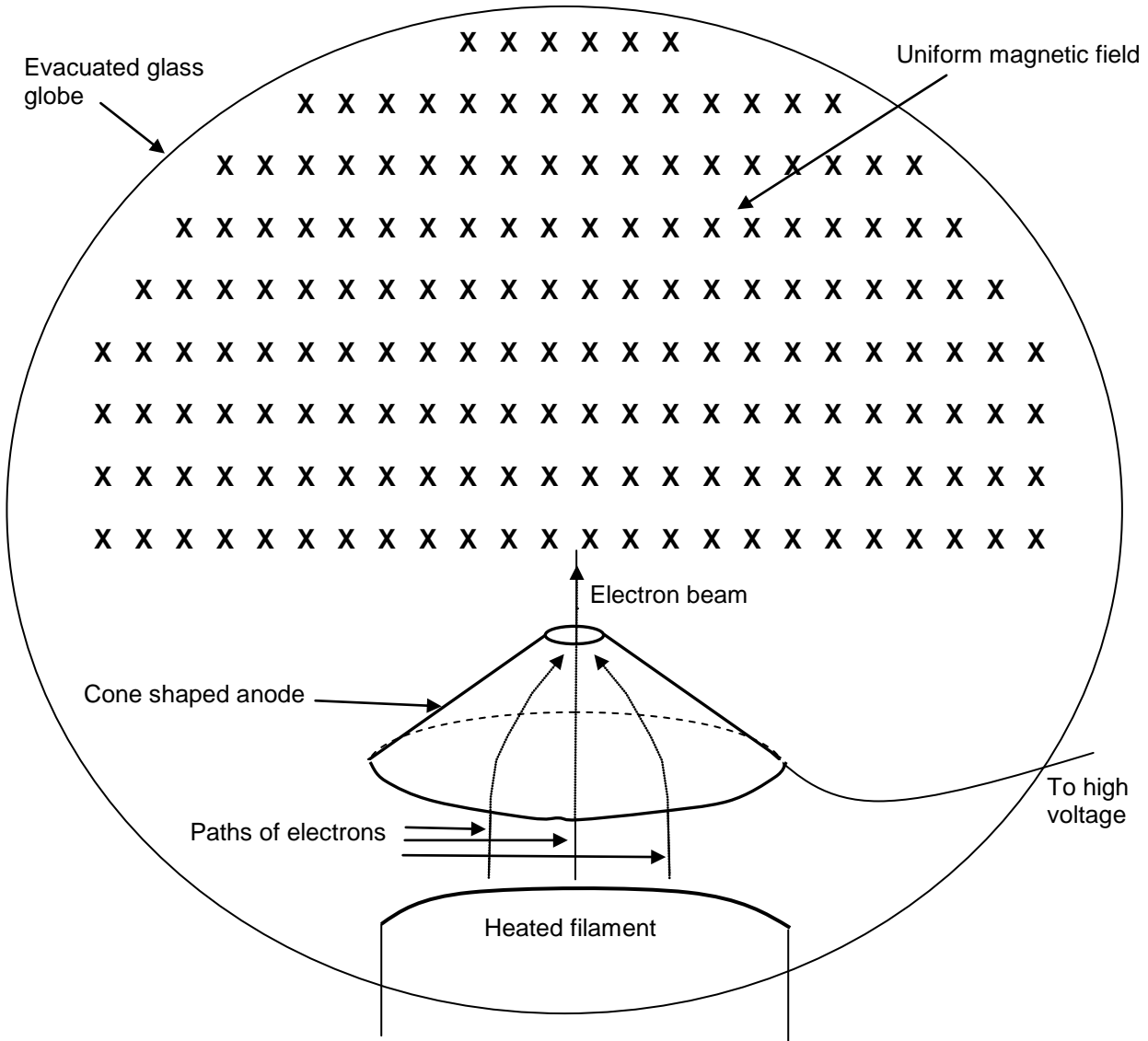

(a) Is the anode positively or negatively charged? Explain your answer.

(2 marks)

(b) Show clearly on the diagram the trajectory of the electron beam whilst in the uniform magnetic field. (2 marks)

(c) Using the equation $F = Bqv$ and an equation for circular motion, show that $r = \frac{mv}{Bq}$.
Show your working. (3 marks)

(d) One experiment using this apparatus gives the following experimental measurements:
electron speed = $2.00 \times 10^7 \text{ m s}^{-1}$
magnetic field strength = $1.20 \times 10^{-3} \text{ T}$
radius of electron path = 10.0 cm.

Use these values to calculate the charge to mass ratio $\frac{q}{m}$ for an electron. (2 marks)

- (e) If the glass bulb is filled with neon gas, a glowing pink ring appears within the globe when the electron beam is turned on. Explain why this glowing ring appears. (3 marks)

Question 14

(10 marks)

John, who has a mass of 80.0 kg, is on a seesaw (that has a mass of 120 kg) with his daughters. Kylie, who has a mass of 30.0 kg, and Lora, who has a mass of 20.0 kg, each sit on a 7.00 m long seesaw. Kylie sits on the right hand side end and holds Lora 50.0 cm in front of her. John then takes a seat on the left hand side of the seesaw.

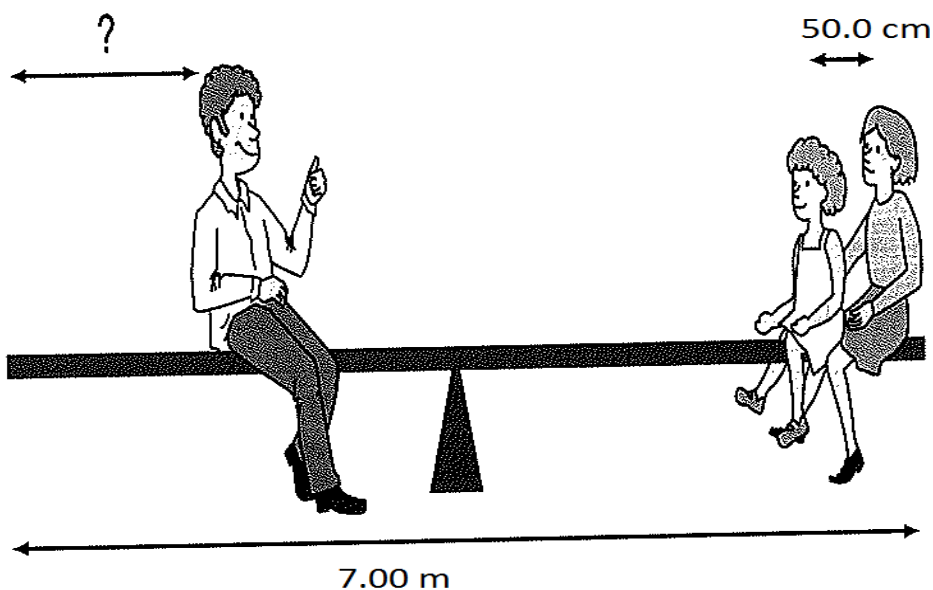

- (a) Draw a free body diagram.

(4 marks)

(b) Where does John need to sit, in respect to the left hand side edge, to balance the seesaw? Show all working. (6 marks)

Question 15

(10 marks)

Juliet is so moved by Romeo's declarations of love that she decides to throw him a token of her love, her favourite teddy bear. He is standing at the edge of a rose garden, 4.50 m below her window and 5.00 m from the base of the wall. The trajectory path is shown by dashed lines on the diagram below. (Show all working for each question).

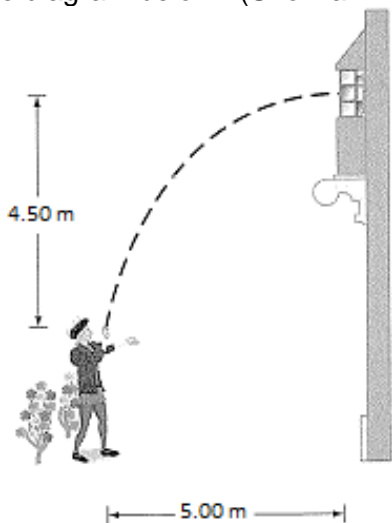

- (a) If Juliet throws her teddy bear horizontally out of her window, how long does Romeo have until he must catch the bear? (3 marks)

- (b) What is the velocity with which Juliet throws the bear at Romeo? (2 marks)

(c) What is the velocity of the bear, just before Romeo catches it?

(5 marks)

Question 16**(10 marks)**

Satellites and space probes can be used in scientific data collection, and are frequently launched from Earth to explore other regions of space.

In an area between Mars and Jupiter there are hundreds and thousands of pieces of rock and space debris known as asteroids, all of them also orbiting the Sun. One of these asteroids is called Eros. In February 2001, the space probe 'Near Shoemaker' landed on Eros. It was the first instance of a space probe landing on an asteroid. The space probe was launched from Earth five years earlier. Before it had landed, it travelled around Eros with its engine off.

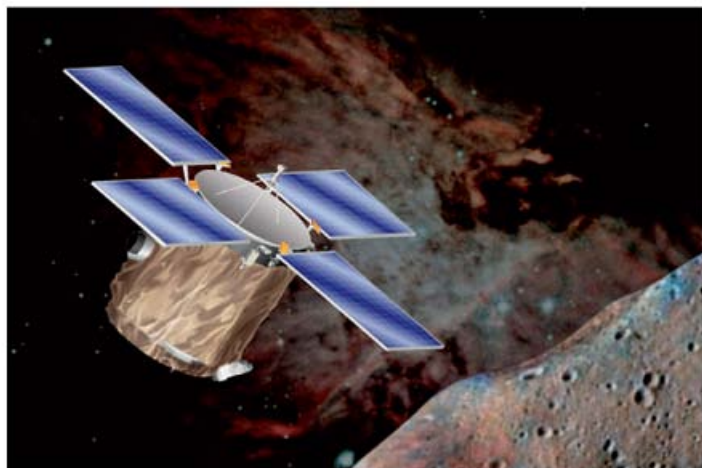

While the space probe was orbiting Eros, it sent back radio signals to Earth. These radio signals took 18 min to reach Earth.

- (a) Calculate the distance between the Earth and the space probe. (2 marks)

At one point the space probe orbited Eros in a circular path, with a constant speed. The radius of the orbit was 196 km, with the period of 9.4 Earth days.

- (b) Calculate the space probes circular speed around Eros. (2 marks)

(c) Calculate the mass of Eros.

(2 marks)

Geosynchronous satellites are generally used for TV and radio transmission, for weather forecasting and as communication relays.

(d) Assuming that the orbit is circular and using your understanding of the period of revolution of a geosynchronous satellite, calculate the height above the Earth's surface such a satellite must orbit. Show all working. (4 marks)

Question 17

(11 marks)

The diagram below shows the trajectory of a projectile which is launched from the top of a building with an initial speed of v_0 at an angle of θ above the horizontal. Five (5) points are marked on the path of this projectile. Answer the following questions; you may annotate the diagram if required. Make sure it is clearly labelled if you make use of it.

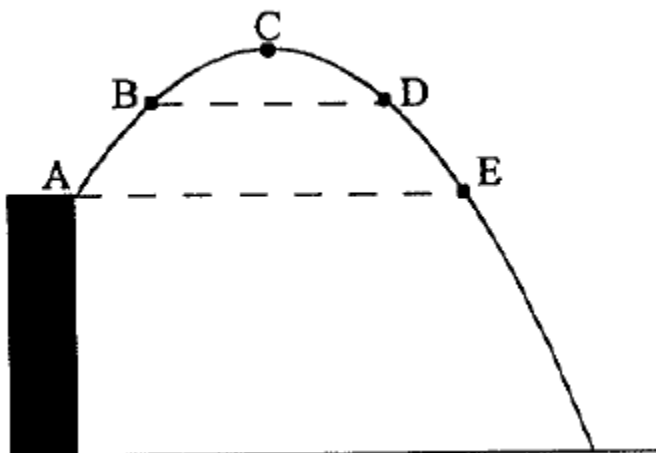

(a) What is the initial horizontal velocity of the projectile? (1 mark)

(b) What is the initial vertical velocity of the projectile? (1 mark)

(c) At which of the marked points, if any, are the speeds of the projectile the same? (2 marks)

(d) At which of the marked points, if any, are the velocities of the projectile the same? (1 mark)

(e) At which of the marked points, if any, is the horizontal velocity zero? (1 mark)

(f) What is the direction of the acceleration at points B and E? (1 mark)

(g) What are the directions of the velocity at points B and E? (2 marks)

(h) What is the magnitude of the vertical velocity at point C? (1 mark)

(i) What is the magnitude of the acceleration at point C? (1 mark)

Question 18**(15 marks)**

An electric motor has a rectangular coil of wire with 150 turns. The coil has length of 90.0 mm and a width of 40.0 mm. The coil carries a current of 0.300 A and is in a magnetic field of strength 0.250 T.

- (a) Draw a diagram to represent the electric motor showing the coil at its position of maximum torque. The current is flowing clockwise through the coil. (2 marks)

- (b) What is the **magnitude** and **direction** of the maximum torque experienced by the coil? (4 marks)

(c) Give three examples of how the torque on this motor could be increased (3 marks)

(d) How does the electric motor **differ** from the electric generator? (2 marks)

(e) Draw a graph to show how the torque changes during one period of rotation of the coil. Indicate on the graph the orientation of the coil when the torque is **maximum** and the orientation when the torque is **zero**. Label both axes. (3 marks)



- (f) A student set up a model generator as in the diagram below. The student turned the coil at slow speed and observed the current produced on a galvanometer. Which one of the following graphs shows the variation of the current with time? (1 mark)

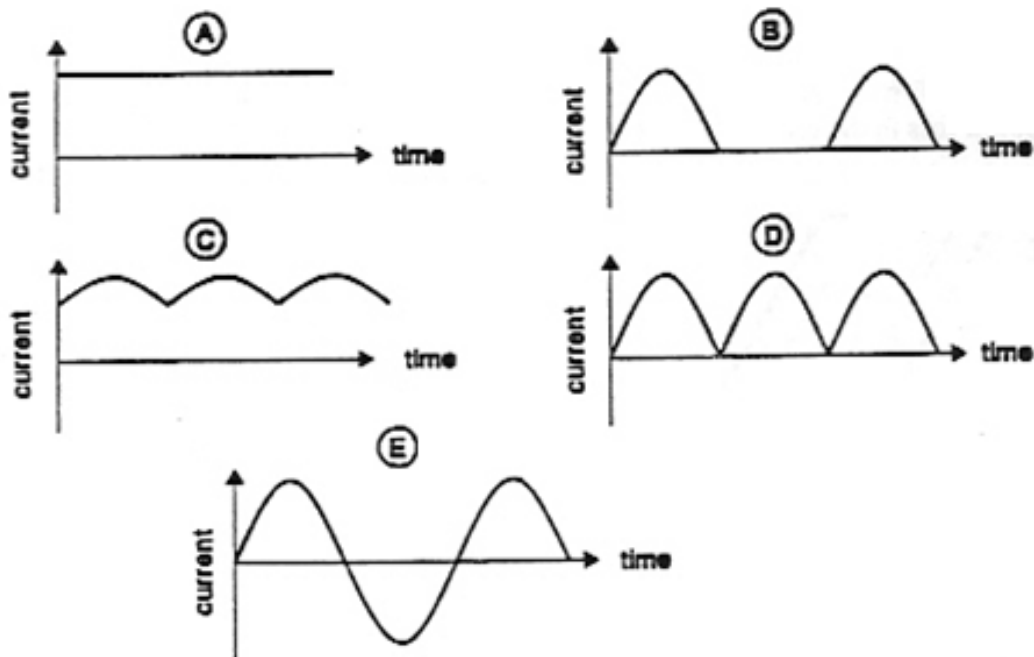
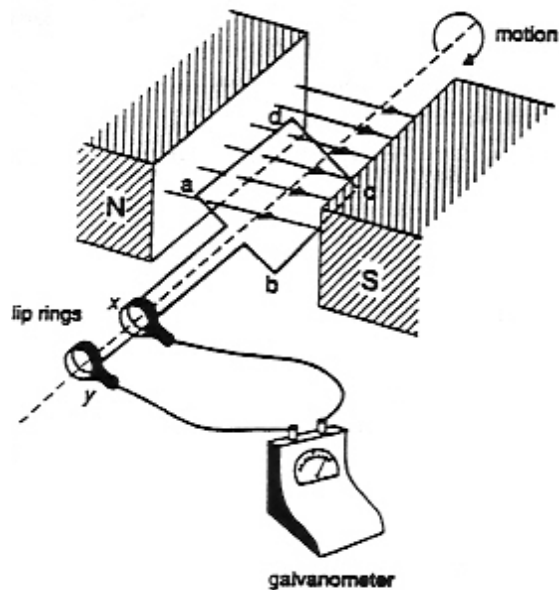

Answer _____

End of Section Two

Section Three: Comprehension**25% (40 Marks)**

This section contains **two (2)** questions. You must answer both questions. Write your answers in the space provided.

Spare pages are included at the end of this booklet. They can be used for planning your responses and/or as additional space if required to continue an answer.

- Planning: If you use the spare pages for planning, indicate this clearly at the top of the page.
- Continuing an answer: If you need to use the space to continue an answer, indicate in the original answer space where the answer is continued, i.e. give the page number. Fill in the number of the question(s) that you are continuing to answer at the top of the page.

Suggested working time for this section is 45 minutes.

Question 19**(28 marks)****The Mars Bar Galaxy – Not To Be Mistaken With The Milky Way**

The visible emission spectrum of a hydrogen atom has three bright lines – red, blue-green and violet. The blue-green line is caused by the emission of a photon as it moves from energy level 4 to energy level 2. The energy of each level (in eV) can be calculated using the formula

$$E_n = \frac{-13.6}{n^2}$$

- (a) What is the energy of the photon emitted (in eV) that causes the blue-green line? (3 marks)

- (b) What is the wavelength of this line in nanometres? (3 marks)

- (c) The blue-green line of the hydrogen spectrum was detected from a close-by galaxy called 'The Mars Bar Galaxy' and was observed at 537.4 nm. The redshift Z can be calculated

$$\text{using } Z = \frac{\lambda_{\text{obs}} - \lambda_{\text{rest}}}{\lambda_{\text{rest}}}$$

Calculate the redshift of the galaxy.

(1 mark)

- (d) For close galaxies receding at a relatively low velocity, like 'The Mars Bar Galaxy', the recessional velocity of the galaxy can be calculated from $Z = \frac{v}{c}$ where c is the speed of light. Use the value of the redshift from (c) to calculate the recessional velocity of the galaxy.

(If you didn't get an answer for (c) use $Z = 0.822$)

(1 mark)

The surface brightness of nebulae can be used to estimate the distance of the nebula from the Earth. The recessional velocity of the nebula can be estimated by the red shift of frequencies emitted in the nebula spectrum. The following data for several nebulae was collected from telescopes on Earth in 1997.

Recessional velocity (km s^{-1})	Distance (D) (megaparsecs)
450	5.0
650	9.6
850	10.8
900	12.0
940	12.6
1080	14.5
1200	16.1
1260	16.6
1350	15.8
1400	18.3

- (e) On a suitable scale, graph the data (with velocity on the y-axis). (3 marks)
- (f) Draw a line of best fit and determine the gradient of the line. The gradient is an estimate of Hubble's constant. (2 marks)

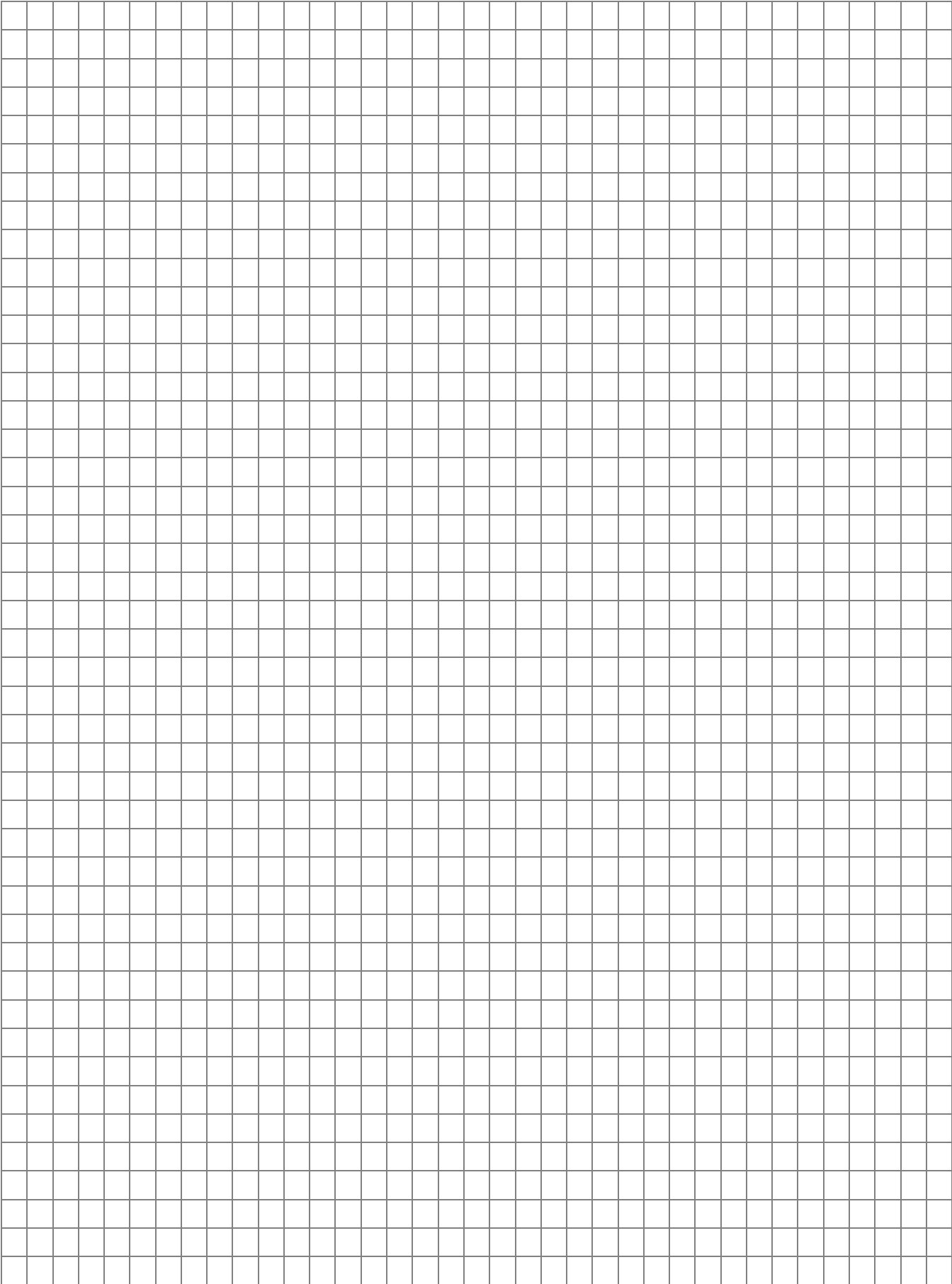

- (g) Using Hubble's law calculate the distance in **light-years** to 'The Mars Bar Galaxy' using the recessional velocity value from part (d). (1 megaparsec = 3261636.26 light-years)
 (If you didn't get an answer for (d) use $v = 2.47 \times 10^6 \text{ m s}^{-1}$)

Hubble's law: $v = H_0 D$

v is the velocity (**in km s^{-1}**), D is the distance (megaparsecs, Mpc), H_0 is Hubble's constant:
 $[H_0 = 74.2 \text{ km s}^{-1} \text{ Mpc}^{-1}]$. (4 marks)

Before satellites and the Hubble Space Telescope were available, stellar parallax was measured from the surface of the Earth using annual parallax as the Earth orbits around the sun. (1 parsec = 3.26156 light-years and is also the distance for which the annual parallax is 1 arcsecond. 1 Earth year = 365.25 solar days).

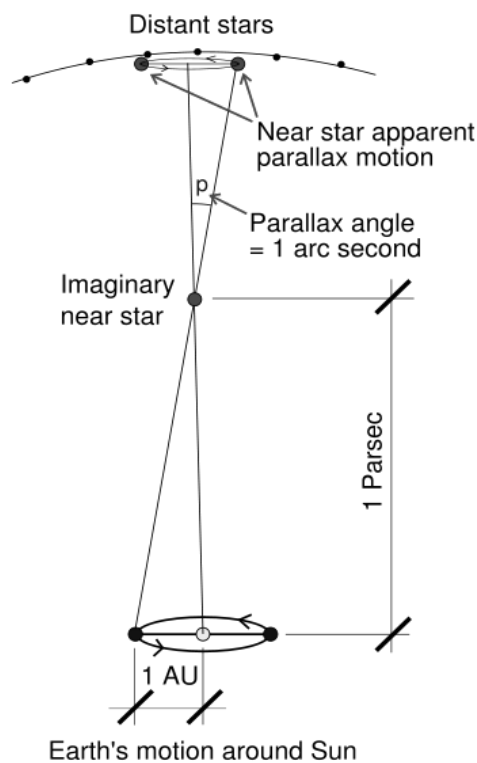

Strain. (2006). *Stellarparallax parsec1* [Diagram]. Retrieved October, 2009, from Wikimedia Commons website: http://commons.wikimedia.org/wiki/File:Stellarparallax_parsec1.svg

(h) If the imaginary star in the diagram above is 1 parsec away, how distant is this star in metres?
(1 mark)

(i) Compass headings are given in degrees, minutes and seconds. What is one second as a decimal of a degree?
(2 marks)

(j) The diagram shows that the Earth's orbit around the sun has a radius of 1 AU. Using your answer in part (h) calculate the radius of the Earth's orbit around the sun in metres. (2 marks)
(If you didn't get an answer for (h) use $D = 2.156 \times 10^{16}$ m)

In 1989, the satellite *Hipparcos* was launched to measure the parallax of nearby stars. It measured the parallax of over 10 000 stars much more accurately than could be done by measurements on Earth. The data for three stars is given below.

Star	Parallax ($\times 10^{-3}$ arcsec)
Sirrah —the brightest star in the constellation of Andromeda	33.60 ± 0.73
Polaris —the north pole star	7.56 ± 0.48
Rigel —the brightest star in the constellation Orion	4.22 ± 0.81

- (k) Calculate the distance to each of these stars in light years and the percentage error. Use the equation $d = 1 / p$, where d = distance (in parsecs), p = parallax angle (in arcsec). (5 marks)

- (l) Suggest why the percentage error of each star's distance measurement is increasing. (1 mark)

Particle Accelerators

The Large Hadron Collider (LHC) at the European Organization for Nuclear Research (CERN) is a gigantic scientific instrument spanning the Swiss-French border near Geneva, Switzerland. The world’s largest and most powerful particle accelerator, it is used by almost 10 000 physicists from more than 80 countries to search for particles to unravel the chain of events that shaped our Universe a fraction of a second after the Big Bang. It could resolve puzzles ranging from the properties of the smallest particles to the biggest structures in the vastness of the Universe.

The actual experiment is a rather simple process: the LHC will collide two hadrons – either protons or lead nuclei - at close to the speed of light. The very high levels of energy involved will allow the kinetic energy of the colliding particles to be transformed into matter, according to Einstein’s law $E=mc^2$, and all matter particles created in the collision will be detected and measured. This experiment will be repeated up to 600 million times per second, for many years. The LHC will mainly perform proton-proton collisions, which will be studied by three of its four detectors (ATLAS, CMS, and LHCb).

They enter the LHC at 99.9997828 % of the speed of light. After acceleration, they reach 99.9999991 %. This is about the maximum speed that can be reached, since nothing can move faster than light, according to the theory of relativity. Although it might seem like an insignificant gain in speed, at close to the speed of light, even a small acceleration results in a large gain in mass, and this is the important part. A motionless proton has a mass of 0.938 GeV (938 million electron volts). The accelerators bring them to a final mass (or energy, which in this case is practically the same thing) of 7000 billion electron volts (7 tera-eV or 7 TeV). If you could – hypothetically – accelerate a person of 100 kg in the LHC, his or her mass would end up being 700 t.

The following graph shows the factor by which mass increases with increasing velocity approaching the speed of light.

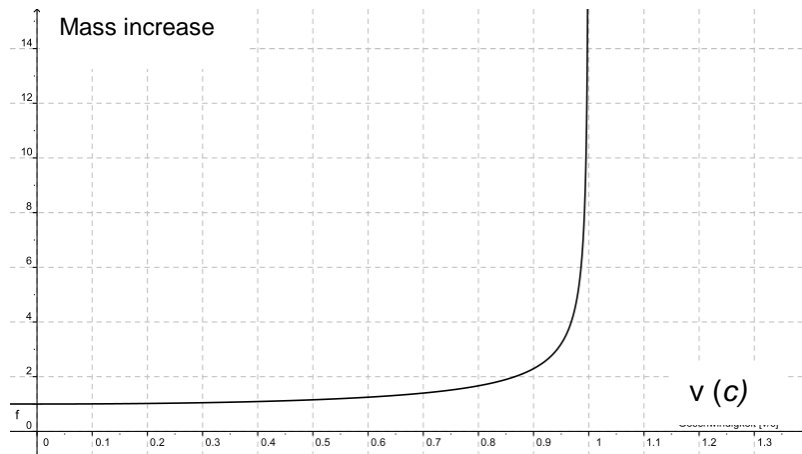

<http://commons.wikimedia.org/wiki/File:Lorentzfaktor.svg>

A proton of mass 1.67×10^{-27} kg is accelerated in the Large Hadron Collider until it reaches $0.95c$ (c = speed of light).

- (a) Estimate the new mass of the proton from the graph. (2 marks)

(b) What is the reason for this apparent increase in mass?

(1 mark)

Einstein derived the mathematical equation showing how mass changes with speed.

$$m_v = \frac{m_0}{\sqrt{1 - \frac{v^2}{c^2}}} \quad \text{where } m_0 \text{ is the rest mass and } m_v \text{ is the mass when moving.}$$

(c) Using the equation above, calculate the mass of the proton when it is moving at $0.99c$.

(2 marks)

(d) Why is it impossible for the proton to travel at or faster than the speed of light?

(2 marks)

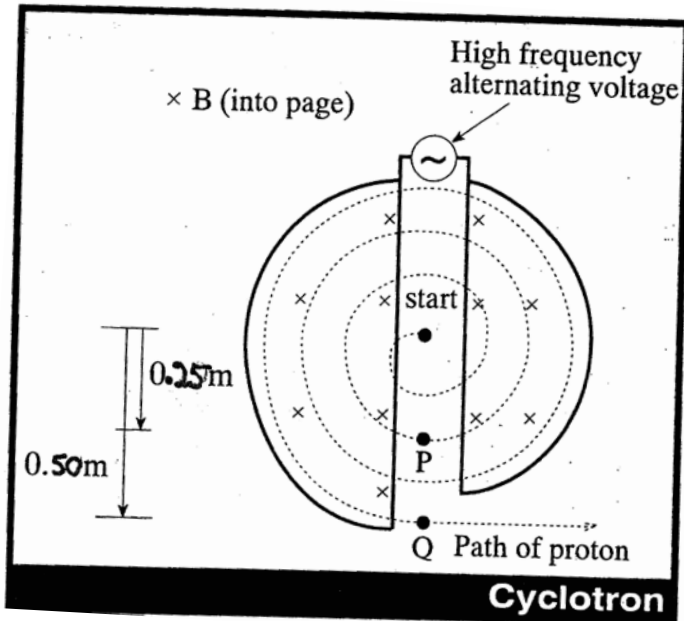

Without external forces, the protons would fly in a straight line. To give them a circular trajectory, the pipes in the LHC are surrounded by a large magnet system that deflects the protons' path – these magnets form an integral part of the LHC and in fact in every circular particle accelerator.

There are many types of particle accelerators including mass spectrometers, synchrotrons and cyclotrons. A cyclotron, which can be found in many hospitals, takes small charged particles such as protons and accelerates them in a circular path to very high speeds. It then releases the particle along a tube to crash into a target substance to make radioisotopes.

The protons start in the centre of the cyclotron and two semi-circular magnetic fields called 'dees', named after their shape, keep them moving in a circular path. An alternating electric field in the gap between the 'dees' accelerates them to higher velocities. The magnetic field strength in the cyclotron is 1.7 T , small compared to the LHC which has a magnetic field strength of 8.33 T , $150\,000$ times larger than the magnetic field of the Earth.

(e) Explain why the radius of the proton's path increases. (2 marks)

(f) Calculate the velocities the proton will have at positions P and Q? (3 marks)

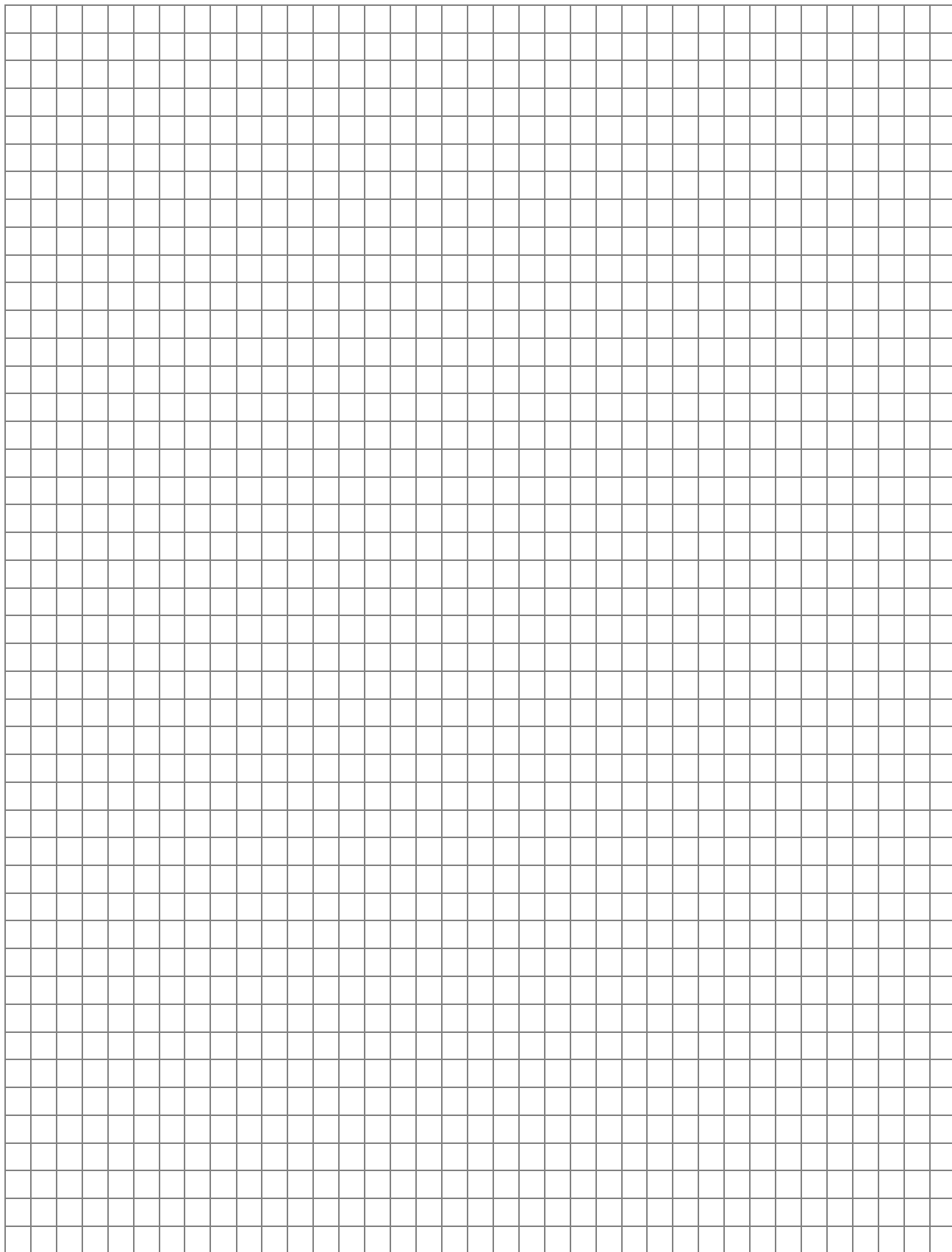

ACKNOWLEDGEMENTS

Landua R, Rau M (2008) The LHC: a step closer to the Big Bang. *Science in School* **10**: 26-33.
www.scienceinschool.org/2008/issue10/lhcwhy

Science Teachers Association of Victoria
<http://www.stav.org.au/>

Shadwick, B., Bhargava, A. (2009) *Dot Point: WACE physics unit 3A and 3B*. Science Press, Marrickville, Australia.

Sofoulis, N. et al (1994) *Year 12 Physics Problems in Context*. Science Teachers Association of Western Australia. Victoria Park, Australia.